

8

7

6

5

4

3

2

1

E

D

C

B

A

E

D

C

B

A

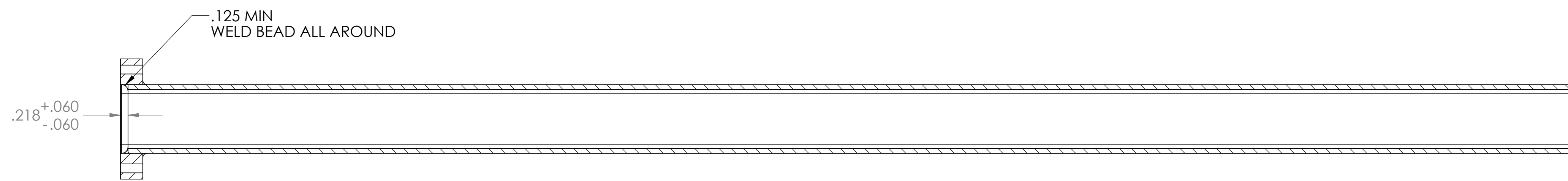

SECTION B-B

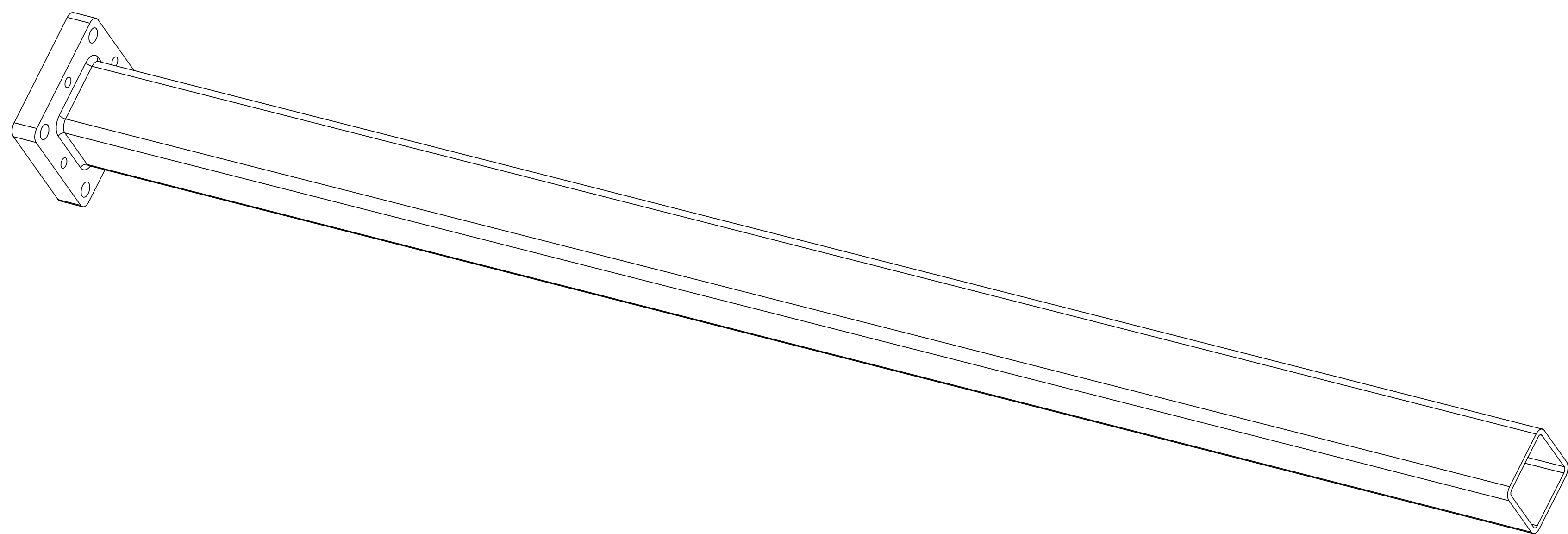
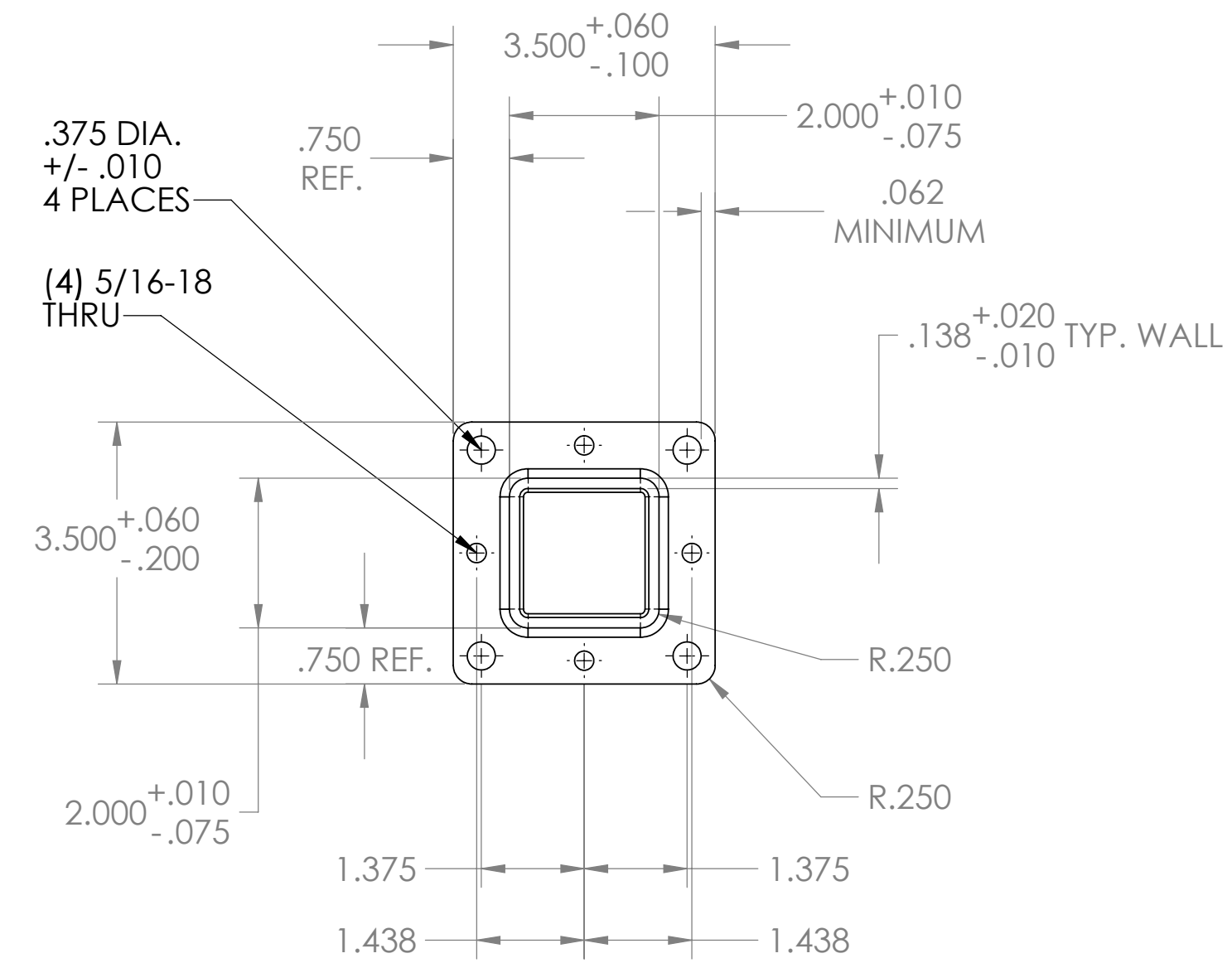

PRODUCT:
 36" HEAVY DUTY BLU-MOUNT
 42" HEAVY DUTY BLU-MOUNT

MATERIAL:
 PLATE: Q235 STEEL WITH DACROMET COATING
 TUBE: Q195 STEEL WITH DACROMET COATING
 WELD: GB/T8110-95 ER50-6

FINISHING:
 BASE COAT: DACROMET (OR EQUIVALENT)
 COATING TO BE APPLIED TO ALL SURFACES INSIDE AND OUTSIDE
 MINIMUM COATING THICKNESS: 8 μm
 MINIMUM COATING WEIGHT: 25 g/m²
 TOP COAT: TGIC POLYESTER POWDER COAT - AAMA 2603 (OR EQUIVALENT)
 COATING TO BE APPLIED TO ALL SURFACES EXCEPT THREADED HOLES AND INSIDE OF POST TUBE
 MINIMUM COATING THICKNESS: 40 μm
 COLOR: LMT BLUE (SAMPLE TO MATCH UPON REQUEST)
 THREADED HOLES SHOULD HAVE NO WELD SPLATTER, DEBRIS, OR EXCESSIVE DACROMET COATING
 BOLT SHOULD BE ABLE TO BE THREADED THROUGH TAPPED HOLES AFTER FINISHING

TESTING REQUIREMENTS:
 REFERENCE LMT WORK INSTRUCTION #WI-QA-055

TOLERANCES UNLESS SPECIFIED	LMT 4" Heavy-Duty Blu-Mount Post Mounts - 36" & 42"	REV
FRACTIONAL ± 1/64		
ANGULAR ± 1/2°		
.XX ± .050		
.XXX ± .020		
.XXXX ± .010		
SHEET DESCRIPTION:		THIRD ANGLE PROJECTION
POST MOUNT POST		
PART DESCRIPTION:		
SCALE: 1-2	MAT: SEE NOTE	SHEET 1 OF 1